



Standard Test Method for Knoop and Vickers Hardness of Materials¹

This standard is issued under the fixed designation E384; the number immediately following the designation indicates the year of original adoption or, in the case of revision, the year of last revision. A number in parentheses indicates the year of last reapproval. A superscript epsilon (ϵ) indicates an editorial change since the last revision or reapproval.

This standard has been approved for use by agencies of the Department of Defense.

^{ε1} NOTE—The title was editorially revised in March 2010.

1. Scope*

1.1 This test method covers determination of the Knoop and Vickers hardness of materials, the verification of Knoop and Vickers hardness testing machines, and the calibration of standardized Knoop and Vickers test blocks.

1.2 This test method covers Knoop and Vickers hardness tests made utilizing test forces in micro (9.807×10^{-3} to 9.807 N) (1 to 1000 gf) and macro (>9.807 to 1176.68 N) (>1 kg to 120 kgf) ranges.

NOTE 1—Previous versions of this standard limited test forces to 9.807 N (1 kg).

1.3 This test method includes all of the requirements to perform macro Vickers hardness tests as previously defined in Test Method E92, Standard Test Method for Vickers Hardness Testing.

1.4 This test method includes an analysis of the possible sources of errors that can occur during Knoop and Vickers testing and how these factors affect the accuracy, repeatability, and reproducibility of test results.

NOTE 2—While Committee E04 is primarily concerned with metals, the test procedures described are applicable to other materials.

1.5 *Units*—When Knoop and Vickers hardness tests were developed, the force levels were specified in units of grams (gf) and kilograms-force (kgf). This standard specifies the units of force and length in the International System of Units (SI); that is, force in Newtons (N) and length in mm or μm . However, because of the historical precedent and continued common usage, force values in gf and kgf units are provided for information and much of the discussion in this standard as well as the method of reporting the test results refers to these units.

¹ This test method is under the jurisdiction of ASTM Committee E04 on Metallography and is the direct responsibility of Subcommittee E04.05 on Micro-indentation Hardness Testing. With this revision the test method was expanded to include the requirements previously defined in E28.92, Standard Test Method for Vickers Hardness Testing of Metallic Material that was under the jurisdiction of E28.06

Current edition approved Feb. 1, 2010. Published February 2010. Originally approved in 1969. Last previous edition approved in 2009 as E384 – 09. DOI: 10.1520/E0384-10.

1.6 *This standard does not purport to address all of the safety concerns, if any, associated with its use. It is the responsibility of the user of this standard to establish appropriate safety and health practices and determine the applicability of regulatory limitations prior to use.*

2. Referenced Documents

2.1 ASTM Standards:²

- C1326 Test Method for Knoop Indentation Hardness of Advanced Ceramics
- C1327 Test Method for Vickers Indentation Hardness of Advanced Ceramics
- E3 Guide for Preparation of Metallographic Specimens
- E7 Terminology Relating to Metallography
- E29 Practice for Using Significant Digits in Test Data to Determine Conformance with Specifications
- E74 Practice of Calibration of Force-Measuring Instruments for Verifying the Force Indication of Testing Machines
- E92 Test Method for Vickers Hardness of Metallic Materials
- E122 Practice for Calculating Sample Size to Estimate, With Specified Precision, the Average for a Characteristic of a Lot or Process
- E140 Hardness Conversion Tables for Metals Relationship Among Brinell Hardness, Vickers Hardness, Rockwell Hardness, Superficial Hardness, Knoop Hardness, and Scleroscope Hardness
- E175 Terminology of Microscopy
- E177 Practice for Use of the Terms Precision and Bias in ASTM Test Methods
- E691 Practice for Conducting an Interlaboratory Study to Determine the Precision of a Test Method
- E766 Practice for Calibrating the Magnification of a Scanning Electron Microscope

² For referenced ASTM standards, visit the ASTM website, www.astm.org, or contact ASTM Customer Service at service@astm.org. For *Annual Book of ASTM Standards* volume information, refer to the standard's Document Summary page on the ASTM website.

*A Summary of Changes section appears at the end of this standard.

2.2 ISO Standards:³

ISO 6507-1 Metallic Materials—Vickers hardness Test—Part 1: Test Method

ISO/IEC 17011 Conformity Assessment—General Requirements for Accreditation Bodies Accrediting Conformity Assessment Bodies.

ISO/IEC 17025 General Requirements for the Competence of Testing and Calibration Laboratories

recovery after force removal. The test results are normally in the Knoop or Vickers scales.

3.2.5 *macroindentation hardness test, n*—a hardness test using a calibrated machine to force an indenter of specific geometry into the surface of the material being evaluated, in which the test forces are normally higher than 9.807 N (1 kgf). Macroindentation test scales include Vickers, Rockwell and Brinell.

NOTE 3—Use of the term microhardness should be avoided because it implies that the hardness, rather than the force or the indentation size, is very low.

3.2.6 *verifying, v*—checking or testing the instrument to assure conformance with the specification.

3.2.7 *Vickers hardness number, HV, n*—an expression of hardness obtained by dividing the force applied to a Vickers indenter by the surface area of the permanent impression made by the indenter.

3.2.8 *Vickers indenter, n*—a square-based pyramidal-shaped diamond indenter with face angles of 136° (see Fig. 1).

3.2.9 *scale, n*—a specific combination of indenter (Knoop or Vickers) and the test force. For example, HV10 is a scale defined as using a Vickers indenter and a 10kg test force and HK0.1 is a scale defined as using a Knoop indenter and a 100gf test force. See 5.8 for the proper reporting of the hardness level and scale.

3.3 *Formulae*—The formulae presented in 5.5 and 5.6 for calculating Knoop and Vickers hardness are based upon an ideal tester. The measured value of the Knoop and Vickers hardness of a material is subjected to several sources of errors. Based on Eq 1-9, variations in the applied force, geometrical variations between diamond indenters, and human errors in measuring indentation lengths can affect the calculated material hardness. The amount influence each of these parameters

3. Terminology

3.1 *Definitions*—For the standard definitions of terms used in this test method, see Terminology E7.

3.2 *Definitions of Terms Specific to This Standard:*

3.2.1 *calibrating, v*—determining the values of the significant parameters by comparison with values indicated by a reference instrument or by a set of reference standards.

3.2.2 *Knoop hardness number, HK, n*—an expression of hardness obtained by dividing the force applied to the Knoop indenter by the projected area of the permanent impression made by the indenter.

3.2.3 *Knoop indenter, n*—a rhombic-based pyramidal-shaped diamond indenter with edge angles of ∠ A = 172° 30' and ∠ B = 130° 0' (see Fig. 2).

3.2.4 *microindentation hardness test, n*—a hardness test using a calibrated machine to force a diamond indenter of specific geometry into the surface of the material being evaluated, in which the test forces are 9.807×10^{-3} to 9.807 N (1 to 1000 gf) and the indentation diagonal, or diagonals are measured with a light microscope after load removal; for any test, it is assumed that the indentation does not undergo elastic

³ Available from International Organization for Standardization (ISO), 1, ch. de la Voie-Creuse, Case postale 56, CH-1211, Geneva 20, Switzerland, http://www.iso.org.

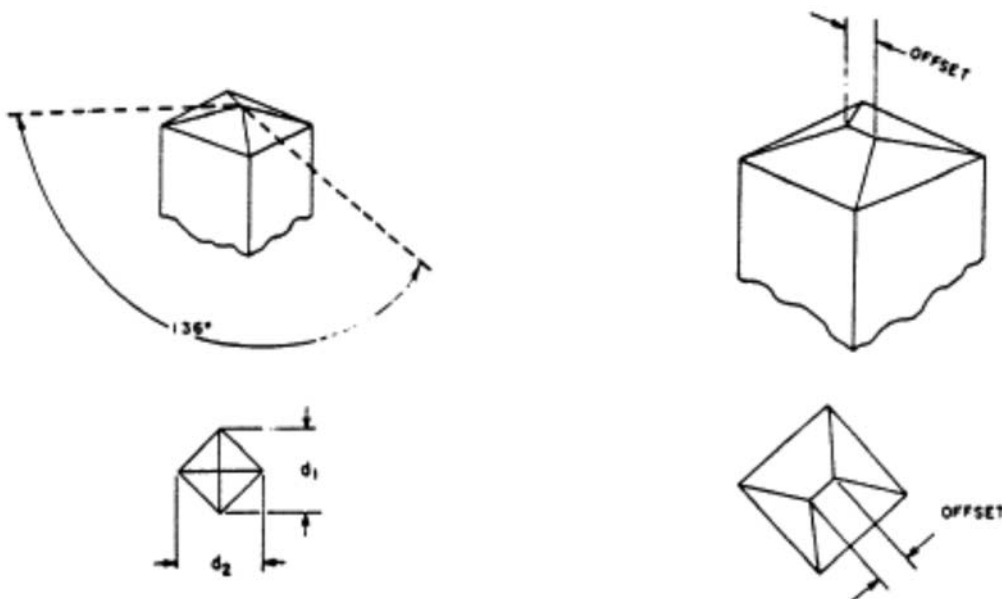

FIG. 1 Vickers Indenter

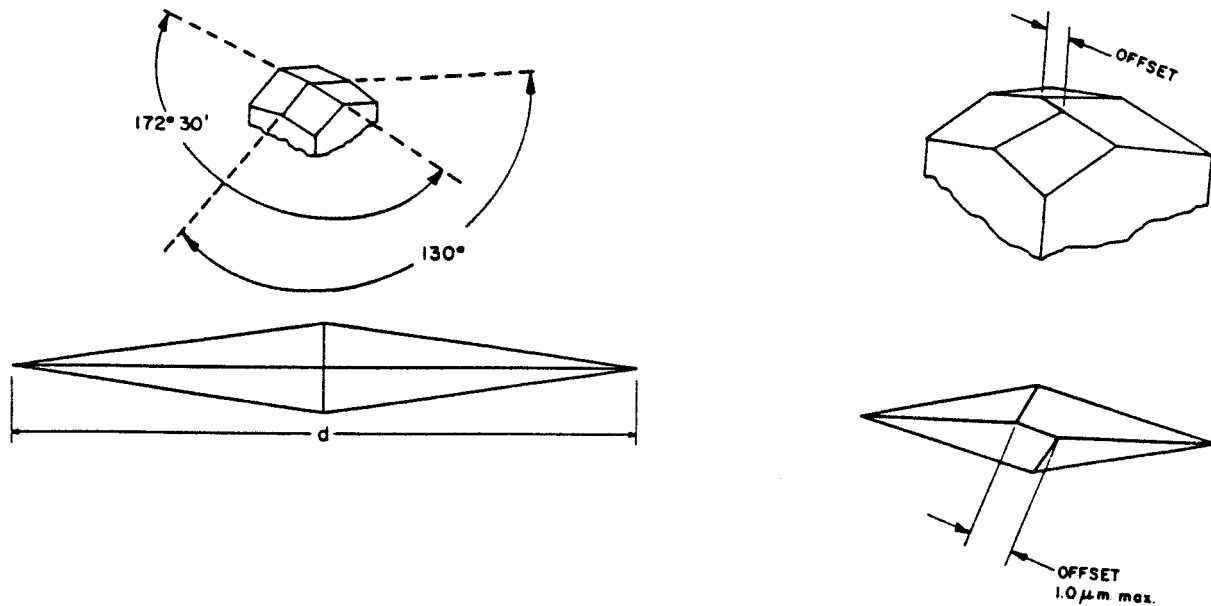

FIG. 2 Knoop Indenter

has on the calculated value of a Knoop or Vickers measurement is discussed in Section 10.

4. Significance and Use

4.1 Hardness tests have been found to be very useful for materials evaluation, quality control of manufacturing processes and research and development efforts. Hardness, although empirical in nature, can be correlated to tensile strength for many metals, and is an indicator of wear resistance and ductility.

4.2 Microindentation hardness tests extend testing to materials that are too thin or too small for macroindentation hardness tests. Microindentation hardness tests also allow specific phases or constituents and regions or gradients too small for macroindentation hardness testing to be evaluated.

4.3 Because the Knoop and Vickers hardness will reveal hardness variations that may exist within a material, a single test value may not be representative of the bulk hardness.

4.4 The Vickers indenter usually produces a geometrically similar indentation at all test forces. Except for tests at very low forces that produce indentations with diagonals smaller than about 25 μm, the hardness number will be essentially the same as produced by Vickers machines with test forces greater than 1 kgf, as long as the material being tested is reasonably homogeneous. For isotropic materials, the two diagonals of a Vickers indentation are equal in size. Recommendations for low force microindentation testing can be found in Appendix X5.

4.5 The Knoop indenter does not produce a geometrically similar indentation as a function of test force. Consequently, the Knoop hardness will vary with test force. Due to its rhombic shape, the indentation depth is shallower for a Knoop indentation compared to a Vickers indentation under identical test conditions. The two diagonals of a Knoop indentation are markedly different. Ideally, the long diagonal is 7.114 times longer than the short diagonal, but this ratio is influenced by

elastic recovery. Thus, the Knoop indenter is very useful for evaluating hardness gradients or thin coatings of sectioned samples.

5. Principle of Test

5.1 In this test method, a Knoop or Vickers hardness number is determined based on the formation of a relatively small indentation made in the test surface of samples being evaluated.

5.2 A Knoop or Vickers indenter, made from diamond of specific geometry, is pressed into the test specimen surface by an accurately controlled applied force using test machines specifically designed for such work.

5.3 Knoop and Vickers hardness testing is divided into micro and macro-test force ranges as defined:

Range	Test Force
Micro	Micro 9.807×10^{-3} to ≤ 9.807 N (1 to ≤ 1000 gf)
Macro	Macro > 9.807 to ≤ 1176.68 N (> 1 to ≤ 120 kgf)

5.3.1 Knoop scale testing is normally performed using micro-range test forces (1kg and less) while the Vickers scale is used over both the micro and macro-ranges.

NOTE 4—The user should consult with the manufacturer before applying test forces in the macro-ranges (over 1 kg) with diamond indenters previously used for micro-range testing. The diamond mount may not be strong enough to support the higher test forces and the diamond may not be large enough to produce the larger indent sizes.

5.4 The size of the indentation is measured using a light microscope equipped with a filar type eyepiece, or other type of measuring device (see Terminology E175). Micro-range indents are typically measured in μm (micrometers) and macro-range indents are measured in mm. The formulas for both units are given below.

5.5 The Knoop hardness number is based upon the force divided by the projected area of the indentation

5.5.1 For Knoop hardness testing, test loads are typically in grams-force (gf) and indentation diagonals are in micrometers